

Dessiné par LKN	Echelle 1:10	Date 16 oct 08	N° plan 308-6274
Désignation Eclaté 3TBG-520	Format A3	Article D1035	
Projet Eclaté TBG (Page 1/4)			

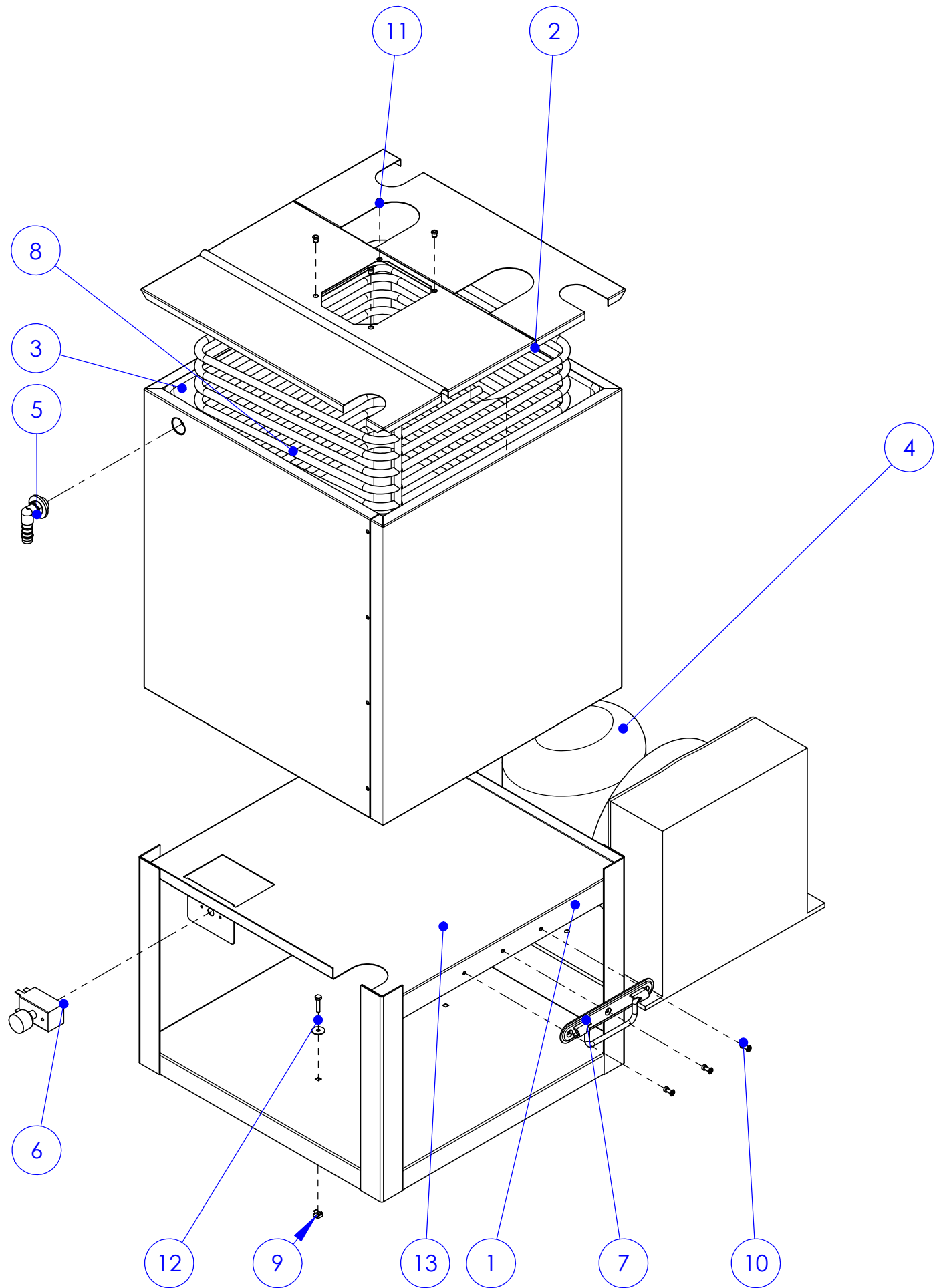

No. ARTICLE	RéfDAV	N°plan	DESCRIPTION	QTE	Material	Finition
1	D4057I	399-2978c	Chassis inox 3TBG	1	430	
2	D2611L	398-2616e	Couvercle 3TBG 7/10	1	EZ	pré-laqué RAL 5008
3	D2205L		Cuve 55L	1		
4	D2951	308-6435	Groupe 3/8Cv CGP12TB1NR	1		
5	D6314P		Douille cannelée coudée	1		
6	D2156		Thermo. Ranc. K50	1		
7	D2631		Poignée groupe TBG	2		
8	I2301		Evapo 55L 3/8cv	1		
9	D2395		Ecrou cage rapide M4	3	inox	
10	D2454		Rivet RAK Ø4x8	6	aluminium	
11	D6451		Insert M4 Tube TARA	4		
12	D2425		Rondelle éventail Ø4	3		
13	D2417		Vis tête hexagonale ISO 4017 M4x20 - 8-8	3	acier	Zinguée
14	D2426		Rondelle plate 4x16x0.8	3	acier	zinguée



Dessiné par	LKN	Echelle	1:10	Date	16 oct 08	N° plan	308-6274
Désignation	Eclaté 3TBG-520			Format	A3	Article	D1035
Projet	Eclaté TBG (Page 2/4)						

Version Standard

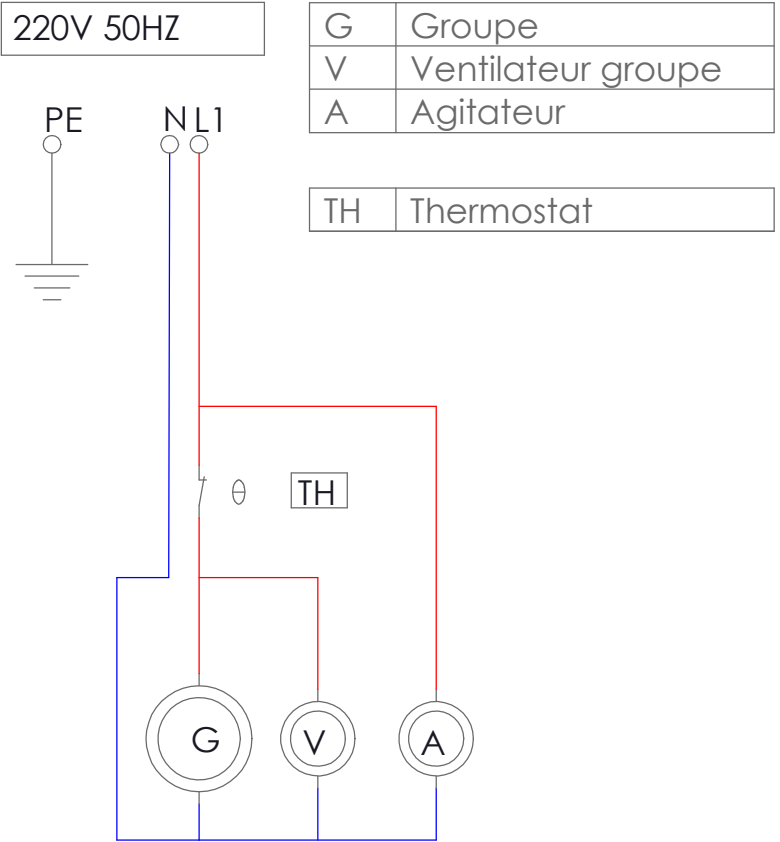

Option - Contrôleur banc de Glace  
- Thermostat électronique

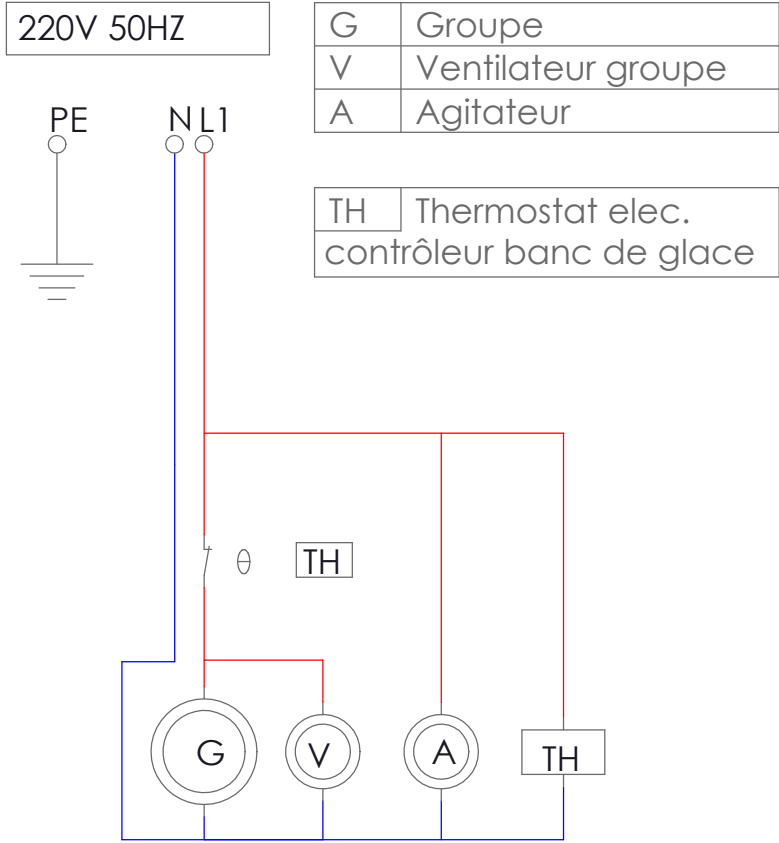

Dessiné par LKN	Echelle 1:10	Date 16 oct 08	N° plan 308-6274
Désignation Eclaté 3TBG-520		Format A3	Article D1035
Projet Eclaté TBG (Page 3/4)			

Code		D1035
Compresseur Compressor	Cv	3/8
Capacité du compresseur Compressor capacity	Cm3	12
Capacité de la cuve Water bath capacity	L	55
Puissance frigorifique à 0°C Cooling capacity at 0°C	W	-
Puissance frigorifique à -10°C Cooling capacity at -10°C	W	520
Taille du banc de glace Ice bank size	Kg	16
Débit de la 1ère heure avec un DT 20° Flow rate 1st hour with DT 20°	L	83
Nbr serpentins carrés 7/8 (longueur max par serpentins) Square coils 7/8 (max length per coil)	Nb	3
Nbr serpentins carrés 15m Square coils 15m	Nb	6
Poids à vide Weight (Dry)	Kg	33
Poids total maxi Total max Weight	Kg	-
Fréquence frequency	Hz	50
Tension voltage	V	220

Courbe de descente en Température du bain d'eau (°C/mn)  
Cooling Curve of the water bath (°C/mn)

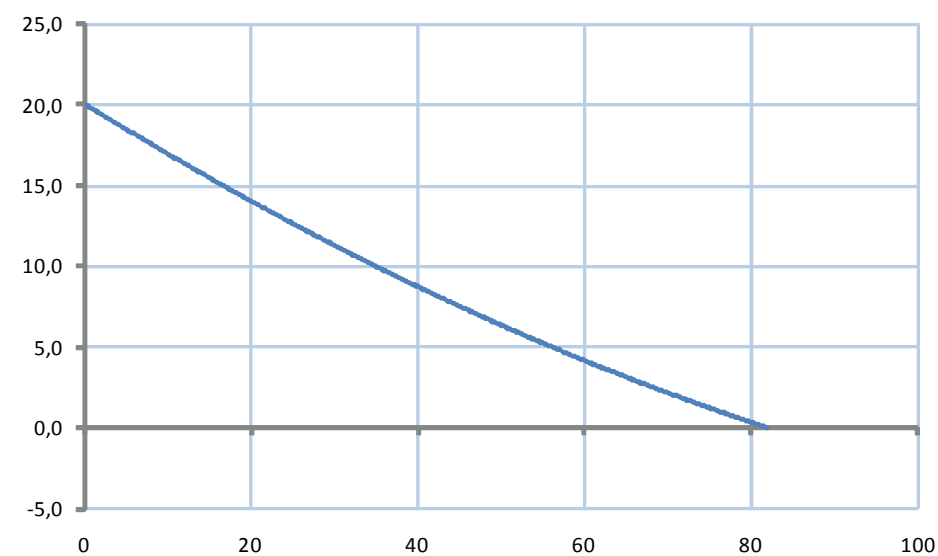

Puissance restituée en fonction de la température du bain d'eau (W/°C)  
Power output related to the water bath temperature (W/°C)

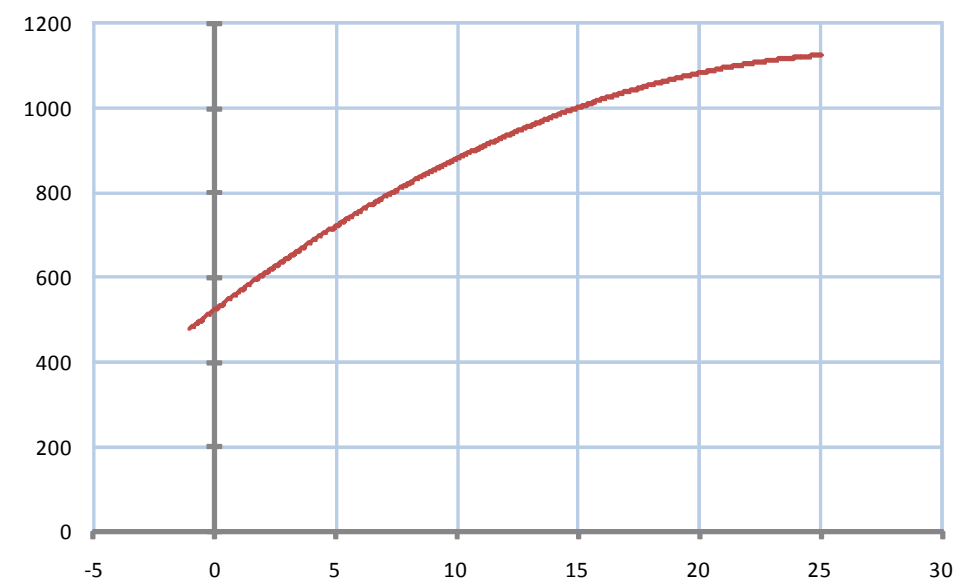

Composant component	Matière material
Evaporateur Evaporator	Cuivre copper
Cuve water bath	Polystirène Choc High-impact Polystyrene
Isolation Insulation	Polyuréthane Polyurethane
Gaz réfrigérant Coolant gas	R134A

Autre other	
Thermostat	Mécanique Mechanical
thermostat digital Digital thermostat	Option option
Ventilateur ventilator	10 W



Dessiné par LKN	Echelle 1:10	Date 16 oct 08	N° plan 308-6274
Désignation Eclaté 3TBG-520		Format A3	Article D1035
Projet Eclaté TBG (Page 4/4)			